

S45H 系列

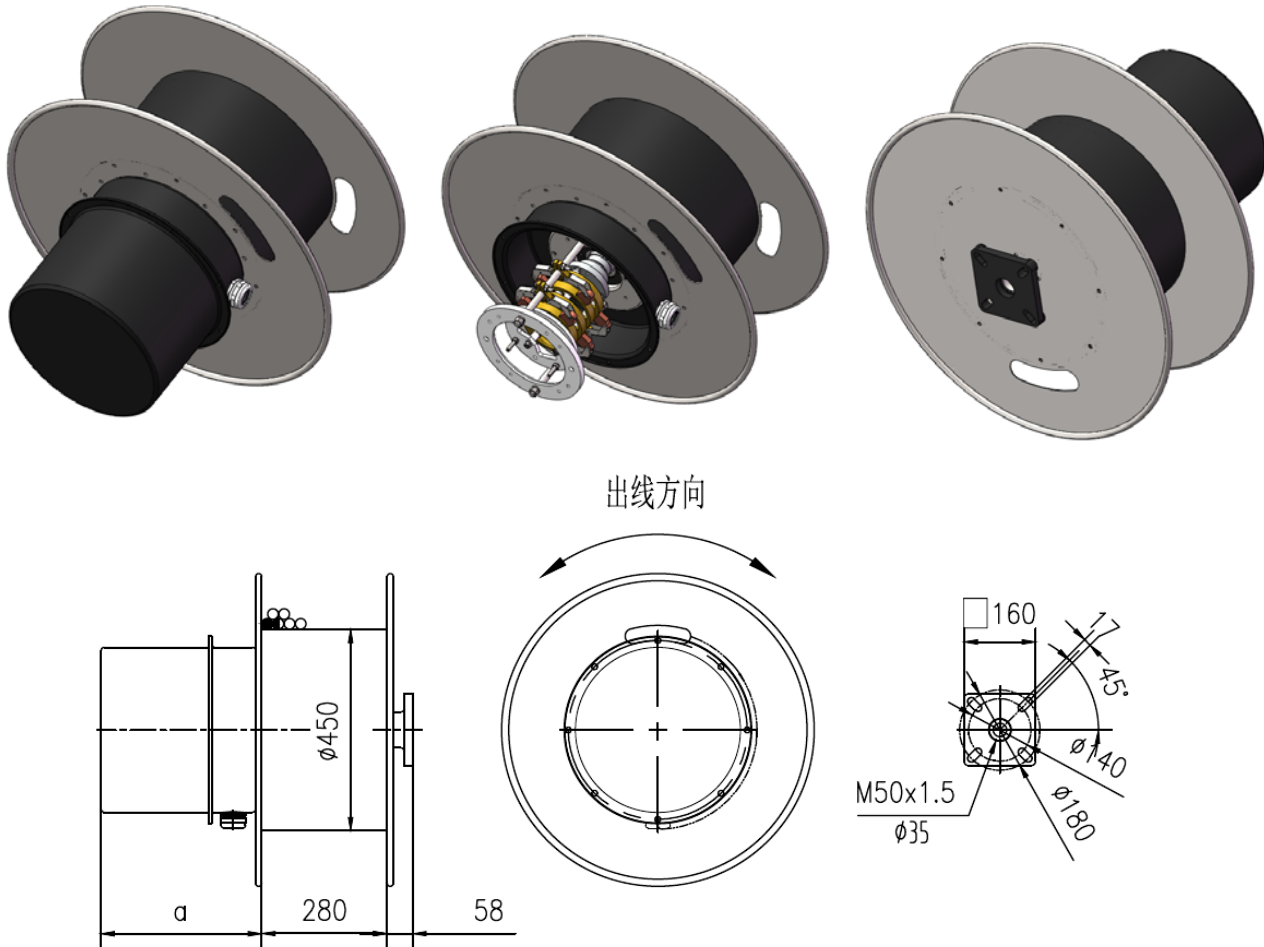

技术参数: Technical parameters:

材料及构造: 卷筒本体及安装法兰采用钢件制造。弹簧为高寿命高等级的弹簧钢。

Materials & Structure: The drum body and mounting flange are made of steel. Spring is the high life high-grade spring steel.

卷绕速度: 水平卷绕 63m/min 垂直卷绕 30m/min

Winding speed: Horizontal : 63m/min Vertical winding: : 30m/min

卷取长度: 水平最大卷绕长度: 87 米, 垂直最大卷绕长度 38 米

Winding length: The Max Horizontal winding length: 65m, The Max Vertical winding length: 30m

电缆参数: 外径 Max $\Phi 35$ mm, 重量 Max 1.6kg/m;

Cable Spec: MaxOD: $\Phi 35$ mm, Max weight: Max 1.6g/m;

电气参数: Vmax 500V, Imax 150A Electric parameter: Vmax 500V, Imax 150A

防护等级: IP54 Grade: IP54



湖南海润电气有限公司

Hunan Hairun Electric Co., Ltd.

地址：湖南省岳阳市麻塘镇

Address: Ma Town, Yueyang City, Hunan Province

电话 (Tel): +86-730-7830777 7832777

传真 (Fax): +86-730-7831777

邮箱 (Email): gs@hinar.com.cn

网址 (Website): <http://www.hinar.com.cn>