

S50H 系列

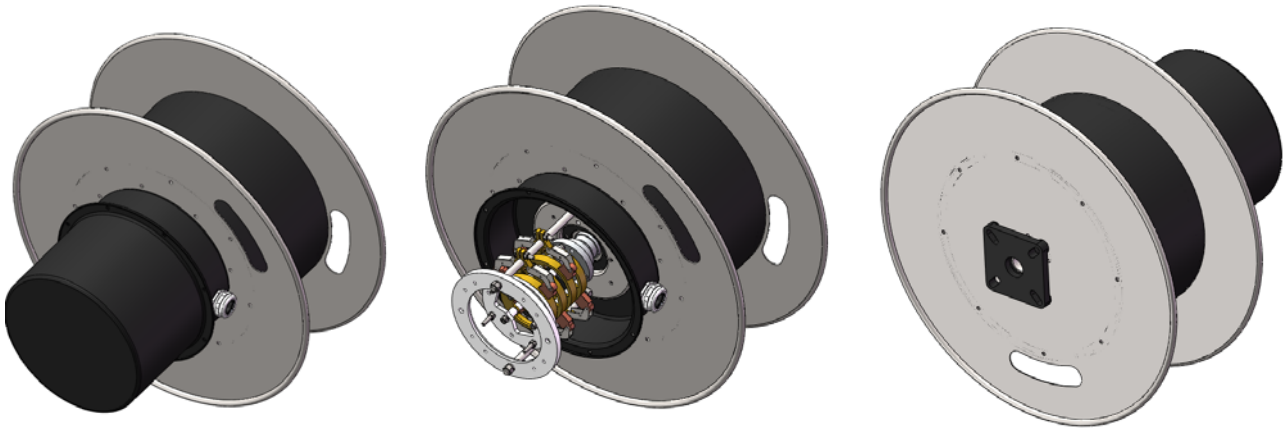

S50M 系列

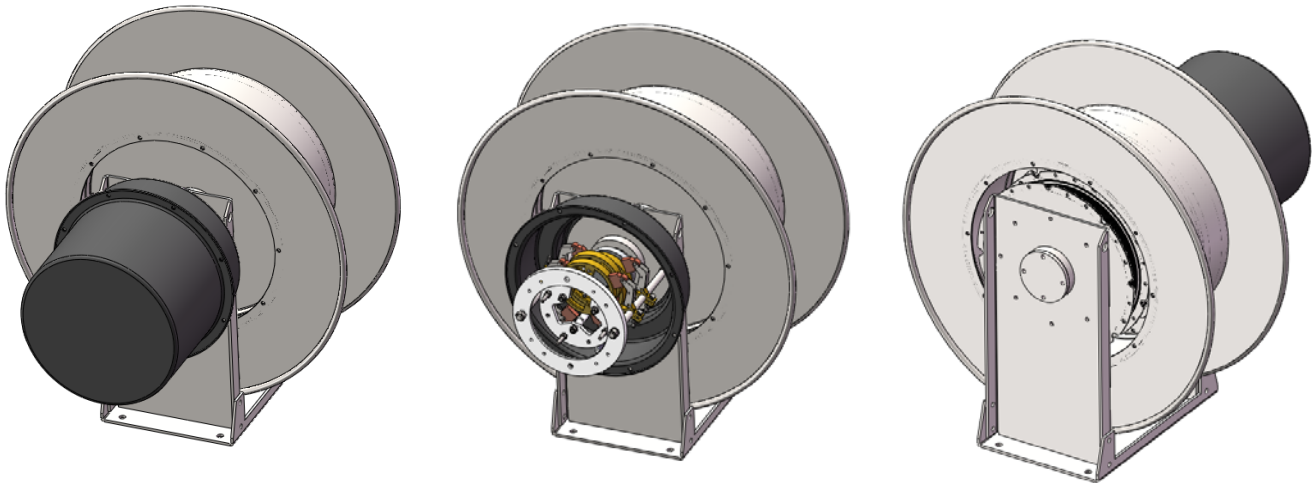

技术参数: Technical parameters:

材料及构造: 卷筒本体及安装法兰采用钢件制造。弹簧为高寿命高等级的弹簧钢。

Materials & Structure: The drum body and mounting flange are made of steel. Spring is the high life high-grade spring steel.

卷绕速度: 水平卷绕 63m/min 垂直卷绕 40m/min

Winding speed: Horizontal : 63m/min Vertical winding: : 30m/min

卷取长度: 水平最大卷绕长度: 70 米, 垂直最大卷绕长度 35 米

Winding length: The Max Horizontal winding length: 70m, The Max Vertical winding length: 35m

电缆参数: 外径 Max $\Phi 40\text{mm}$, 重量 Max 2.5kg/m;

Cable Spec: MaxOD: $\Phi 40\text{mm}$, Max weight: Max 2.5kg/m;

电气参数: $V_{\text{max}} 500\text{V}$, $I_{\text{max}} 200\text{A}$

Electric parameter: $V_{\text{max}} 500\text{V}$, $I_{\text{max}} 200\text{A}$

防护等级: IP54

Grade: IP54

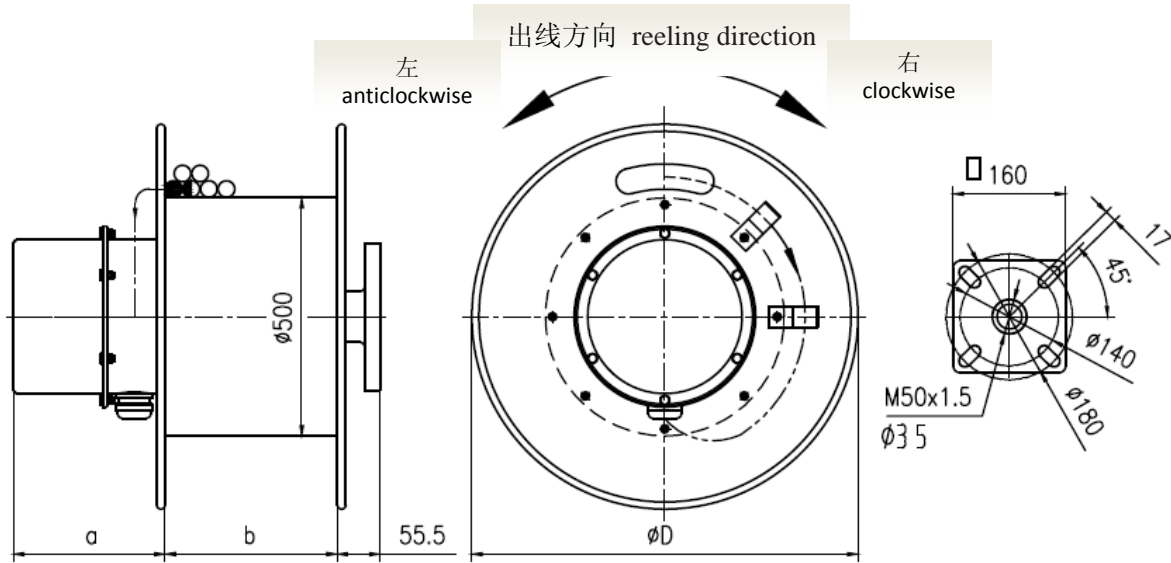
S50H 型选型表
S50H type Selection Tables for Reels

 Application: **A** Vertical **D** Horizontal and Vertical Retrieval

| 电缆 Cable | 卷取 方式 | 电缆长度 Lw/Li (m) | 卷筒型号 Reel type | D (mm) | a (mm) | b (mm) | 滑环箱 Slipring- body | 法兰 Flange type |
|--|----------|-------------------|-------------------|-----------|-----------|-----------|--------------------------|----------------------|
| 30*1.5mm ² 25mm 0.893kg/m | A | 16/1.5 | S50H7028-0530-1A | 700 | 320 | 280 | 3 | 2 |
| | D | 22/1.5 | S50H7028-0530-1A | 700 | 320 | 280 | 3 | 2 |
| | A | 22/1.5 | S50H8028-0530-2P | 800 | 320 | 280 | 3 | 2 |
| | D | 48/1.5 | S50H8028-0530-2S | 800 | 320 | 280 | 3 | 2 |
| | A | 35/1.5 | S50H7036-0530-2SP | 700 | 320 | 340 | 3 | 2 |
| | D | 75/1.5 | S50H9028-0530-3S | 900 | 320 | 280 | 3 | 2 |
| 36*1.5mm ² 27.5mm 0.995kg/m | A | 16/1.5 | S50H7028-0536-1A | 700 | 350 | 280 | 3 | 2 |
| | D | 22/1.5 | S50H7028-0536-1A | 700 | 350 | 280 | 3 | 2 |
| | A | 22/1.5 | S50H7028-0536-2P | 700 | 350 | 280 | 3 | 2 |
| | D | 48/1.5 | S50H9028-0536-2S | 900 | 350 | 280 | 3 | 2 |
| | A | 32/1.5 | S50H8036-0536-2SP | 800 | 350 | 340 | 3 | 2 |
| | D | 75/1.5 | S50H9028-0536-3S | 900 | 350 | 280 | 3 | 2 |
| 42*1.5mm ² 30mm 1.417kg/m | A | 14/1.5 | S50H8028-0542-1A | 800 | 380 | 280 | 3 | 2 |
| | D | 22/1.5 | S50H8028-0542-1A | 800 | 380 | 280 | 3 | 2 |
| | A | 22/1.5 | S50H8028-0542-2P | 800 | 380 | 280 | 3 | 2 |
| | D | 50/1.5 | S50H9028-0542-2S | 900 | 380 | 280 | 3 | 2 |
| | D | 68/1.5 | S50H9028-0542-3S | 900 | 380 | 280 | 3 | 2 |

| 电缆 Cable | 卷取 方式 | 电缆长度 Lw/Li (m) | 卷筒型号 Reel type | D (mm) | a (mm) | b (mm) | 滑环箱 Slipring- body | 法兰 Flange type |
|--|----------|-------------------|-------------------|-----------|-----------|-----------|--------------------------|----------------------|
| 24*2.5mm ² 22.5mm 0.875kg/m | A | 18/1.5 | S50H7028-0524-1A | 700 | 290 | 280 | 3 | 2 |
| | D | 22/1.5 | S50H7028-0524-1A | 700 | 290 | 280 | 3 | 2 |
| | A | 22/1.5 | S50H7028-0524-2P | 700 | 290 | 280 | 3 | 2 |
| | D | 45/1.5 | S50H9028-0524-2S | 900 | 290 | 280 | 3 | 2 |
| | A | 37/1.5 | S50H7036-0524-2SP | 700 | 290 | 340 | 3 | 2 |
| | D | 72/1.5 | S50H8028-0524-3S | 800 | 290 | 280 | 3 | 2 |
| 30*2.5mm ² 29mm 1.306kg/m | A | 14/1.5 | S50H7028-0530-1A | 700 | 320 | 280 | 3 | 2 |
| | D | 22/1.5 | S50H8028-0530-1A | 800 | 320 | 280 | 3 | 2 |
| | A | 22/1.5 | S50H8028-0530-2P | 800 | 320 | 280 | 3 | 2 |
| | D | 50/1.5 | S50H9028-0530-2S | 900 | 320 | 280 | 3 | 2 |
| | D | 70/1.5 | S50H9028-0530-3S | 900 | 320 | 280 | 3 | 2 |
| 36*2.5mm ² 31.2mm 1.635kg/m | A | 13/1.5 | S50H7028-0536-1A | 700 | 350 | 280 | 3 | 2 |
| | D | 23/1.5 | S50H8028-0536-1A | 800 | 350 | 280 | 3 | 2 |
| | A | 19/1.5 | S50H8028-0536-2P | 800 | 350 | 280 | 3 | 2 |
| | D | 50/1.5 | S50H9028-0536-2S | 900 | 350 | 280 | 3 | 2 |
| | A | 23/1.5 | S50H8028-0532-3P | 800 | 350 | 280 | 3 | 2 |
| | D | 66/1.5 | S50H9028-0536-3S | 900 | 350 | 280 | 3 | 2 |
| 4*16mm ² 24mm 1.104kg/m | A | 17/1.5 | S50H7028-1204-1A | 700 | 350 | 280 | 4 | 2 |
| | D | 23/1.5 | S50H7028-1204-1A | 700 | 350 | 280 | 4 | 2 |
| | A | 23/1.5 | S50H7028-1204-2P | 700 | 350 | 280 | 4 | 2 |
| | D | 47/1.5 | S50H8028-1204-2S | 800 | 350 | 280 | 4 | 2 |
| | A | 30/1.5 | S50H7028-1205-2SP | 700 | 350 | 340 | 4 | 2 |
| | D | 72/1.5 | S50H8028-1204-3S | 800 | 350 | 280 | 4 | 2 |
| 5*16mm ² 26mm 1.181kg/m | A | 16/1.5 | S50H7028-1205-1A | 700 | 385 | 280 | 4 | 2 |
| | D | 22/1.5 | S50H8028-1205-1A | 800 | 385 | 280 | 4 | 2 |
| | A | 22/1.5 | S50H8028-1205-2P | 800 | 385 | 280 | 4 | 2 |
| | D | 47/1.5 | S50H8028-1205-2S | 800 | 385 | 280 | 4 | 2 |
| | A | 27/1.5 | S50H8028-1205-2SP | 800 | 385 | 340 | 4 | 2 |
| | D | 75/1.5 | S50H9028-1205-3S | 900 | 385 | 280 | 4 | 2 |
| 4*25mm ² 28.9mm 1.623kg/m | A | 14/1.5 | S50H7028-1204-1A | 700 | 350 | 280 | 4 | 2 |
| | D | 22/1.5 | S50H8028-1204-1S | 800 | 350 | 280 | 4 | 2 |
| | A | 20/1.5 | S50H8028-1204-2P | 800 | 350 | 280 | 4 | 2 |
| | D | 50/1.5 | S50H9028-1204-2S | 900 | 350 | 280 | 4 | 2 |
| | A | 23/1.5 | S50H8028-1204-3P | 800 | 350 | 280 | 4 | 2 |
| | D | 70/1.5 | S50H9028-1204-3S | 900 | 350 | 280 | 4 | 2 |



海润电气有限公司

Hunan Hairun Electric Co., Ltd.

地址：湖南省岳阳市麻塘镇

Address: Ma Town, Yueyang City, Hunan Province

电话 (Tel): +86-730-7830777 7832777

传真 (Fax): +86-730-7831777

邮箱 (Email): gs@hinar.com.cn

网址 (Website): <http://www.hinar.com.cn>